

Husky 205 Plastic Pumps

Air-Operated Double Diaphragm

Ordering Information

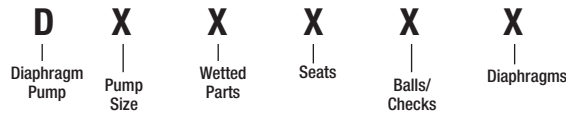

PUMP SIZE (AIR MOTOR TYPE AND MATERIAL)	WETTED PARTS	SEATS	CHECK VALVES	DIAPHRAGM
1 = 1/4" (6.35 mm) Standard: polypropylene center section 2 = 1/4" (6.35 mm) Remote: polypropylene center section	1 = Acetal (npt) 2 = Poly (npt) 5 = PVDF (npt)	0 = No Seats	2 = Acetal 9 = Polypropylene A = PVDF	1 = PTFE 6 = Santoprene

Popular Models

Material	Part Number (NPT Ported)		Part Number (BSP Ported)		Materials for Check Valves	Materials for Diaphragms	Fluid Kit	Air Kit	Air Control**
	Standard Air Valve	Remote* Air Valve	Standard Air Valve	Remote* Air Valve					
Acetal	D11021	D21021	D11021	D21021	Acetal	PTFE	D01021	238853	246946
	D11026	D21026	D11026	D21026	Acetal	Santoprene	D01026	238853	246946
PVDF	D150A1	D250A1	D150A1	D250A1	PVDF	PTFE	D010A1	238853	246946
	D150A6	D250A6	D150A6	D250A6	PVDF	Santoprene	D010A6	238853	246946
Polypropylene	D12091	D22091	D12091	D22091	Polypropylene	PTFE	D01091	238853	246946
	D12096	D22096	D12096	D22096	Polypropylene	Santoprene	D01096	238853	246946

* Requires Cycleflo or external valve control

** Air control includes air regulator and filter with gauge

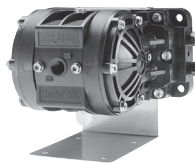

Wall bracket standard with pump

Technical Specifications

Husky 205 Plastic Pumps	Acetal	Polypropylene	PVDF
Maximum fluid working pressure	100 psi (7 bar, 0.7 MPa)	100 psi (7 bar, 0.7 MPa)	100 psi (7 bar, 0.7 MPa)
Maximum free flow delivery*	5.0 gpm (18.9 lpm)	5.0 gpm (18.9 lpm)	5.0 gpm (18.9 lpm)
Maximum pump speed	250 cpm	250 cpm	250 cpm
Displacement per cycle**	0.012 gallon (0.045 liter)	0.012 gallon (0.045 liter)	0.012 gallon (0.045 liter)
Maximum suction lift (D12096)	10 ft (3 m) dry	10 ft (3 m) dry	10 ft (3 m) dry
Maximum size pumpable solids	0.06 in (1.5 mm)	0.06 in (1.5 mm)	0.06 in (1.5 mm)
Maximum ambient operating temperature***	180°F (82°C)	150°F (66°C)	180°F (82°C)
Maximum diaphragm operating temperature***	Refer to page 7	Refer to page 7	Refer to page 7
Typical sound level at 70 psi (4.9 bar, 0.49 MPa) air @ 125 cpm	70 dBa	70 dBa	70 dBa
Maximum air consumption	9.0 scfm (0.252 m3/min)	9.0 scfm (0.252 m3/min)	9.0 scfm (0.252 m3/min)
Air pressure operating range	20 to 100 psi (1.4 to 7 bar, 0.14 to 0.7 MPa)	20 to 100 psi (1.4 to 7 bar, 0.14 to 0.7 MPa)	20 to 100 psi (1.4 to 7 bar, 0.14 to 0.7 MPa)
Air inlet size	1/4 npt(f)	1/4 npt(f)	1/4 npt(f)
Air exhaust port size	1/4 npt(f)	1/4 npt(f)	1/4 npt(f)
Fluid inlet & outlet size****	1/4 npt(f)	1/4 npt(f)	1/4 npt(f)
Weight	2.5 lb (1.1 kg)	2.0 lb (0.9 kg)	2.8 lb (1.3 kg)
Wetted parts (in addition to ball, seat and diaphragm materials– which may vary by pump)	Acetal with Stainless Steel fibers, PTFE, Acetal, Santoprene	Glass-filled Polypropylene, Santoprene, PTFE, Polypropylene	PVDF, PTFE, Santoprene
Instruction manual	308652	308652	308652

** Displacement per cycle may vary based on suction condition, discharge head, air pressure and fluid type

*** Actual pump performance may be affected by prolonged usage at temperature

**** Hybrid thread allows for either 1/4 npt or 1/4 bspt fitting

Husky 205 Plastic Pumps

Performance Charts

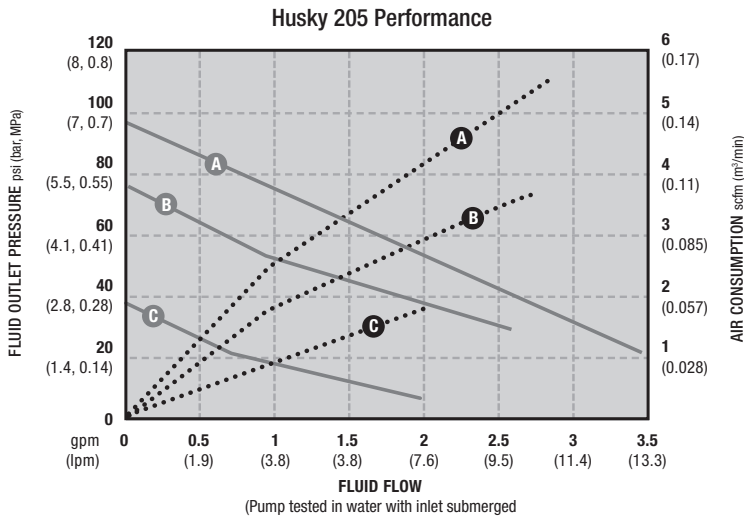

AIR PRESSURE	LEGEND
A = at 100 psi (7 bar, 0.7 MPa)	Air Consumption.....
B = at 70 psi (4.8 bar, 0.48 MPa)	Fluid Pressure ———
C = at 40 psi (2.8 bar, 0.28 MPa)	

Dimensions

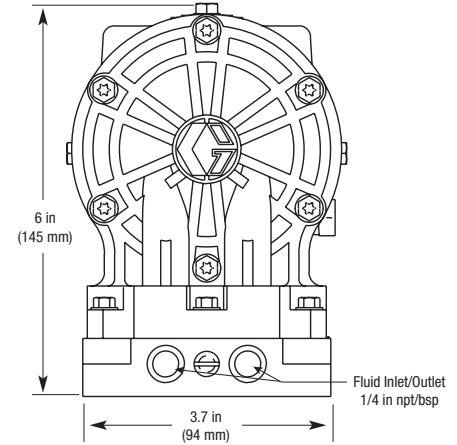
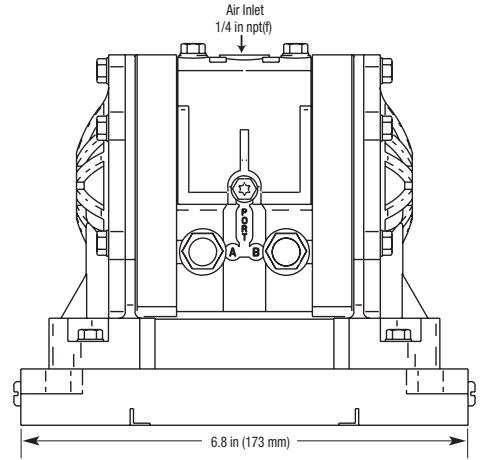

Typical System Drawings

Husky 205 Wall-Mount
(shown with CycleFlo controller)

