

Husky 307 Plastic Pumps

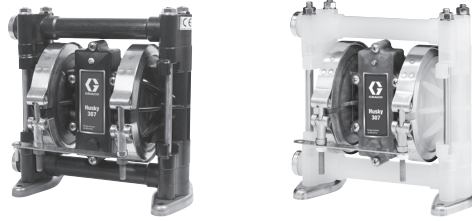

Technical Specifications

Husky 307 Plastic Pumps	Acetal	Polypropylene
Maximum fluid working pressure	100 psi (7 bar, 0.7 MPa)	100 psi (7 bar, 0.7 MPa)
Maximum free flow delivery*	7.0 gpm (26.5 lpm)	7.0 gpm (26.5 lpm)
Maximum pump speed	330 cpm	330 cpm
Displacement per cycle**	0.02 gallon (0.076 liter)	0.02 gallon (0.076 liter)
Maximum suction lift (D31255)	12 ft (3.7 m) dry	12 ft (3.7 m) dry
Maximum size pumpable solids	0.06 in (1.5 mm)	0.06 in (1.5 mm)
Maximum ambient operating temperature***	180°F (65.5°C)	150°F (65.5°C)
Maximum diaphragm operating temperature***	Refer to page 7	Refer to page 7
Typical sound level at 50 psi (3.5 bar, 0.35 MPa) air @ 50 cpm	75 dBa	75 dBa
Maximum air consumption	6 scfm (0.17 m3/min)	6 scfm (0.17 m3/min)
Air pressure operating range	20 to 100 psi (1.4 to 8.4 bar, 0.14 to 0.84 MPa)	20 to 100 psi (1.4 to 8.4 bar, 0.14 to 0.84 MPa)
Air inlet size	1/4 npt(f) or bspt(f)	1/4 npt(f) or bspt(f)
Fluid inlet & outlet size****	3/8 npt(f)	3/8 npt(f)
Weight	5.2 lb (2.4 kg)	4.75 lb (2.2 kg)
Wetted parts (in addition to ball, seat and diaphragm materials—which may vary by pump)	Acetal with Stainless Steel fibers, PTFE	Polypropylene, PTFE
Instruction manual	308553	308553

*Flow rates are with muffler and do not vary based on diaphragm material

**Displacement per cycle may vary based on suction condition, discharge head, air pressure and fluid type

***Actual pump performance may be affected by prolonged usage at temperature

Performance Chart

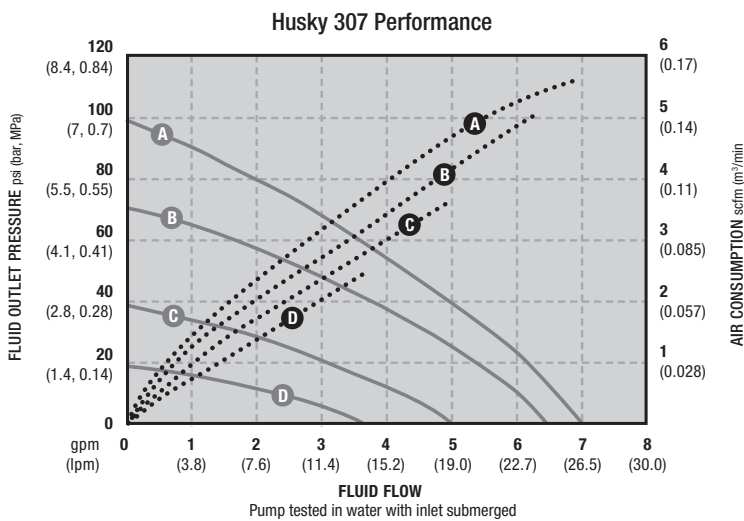

AIR PRESSURE	LEGEND
Ⓐ = at 100 psi (7 bar, 0.7 MPa)	Air Consumption.....
Ⓑ = at 70 psi (4.8 bar, 0.48 MPa)	Fluid Pressure ———
Ⓒ = at 40 psi (2.8 bar, 0.28 MPa)	
Ⓓ = at 20 psi (1.4 bar, 0.14 MPa)	

Dimensions

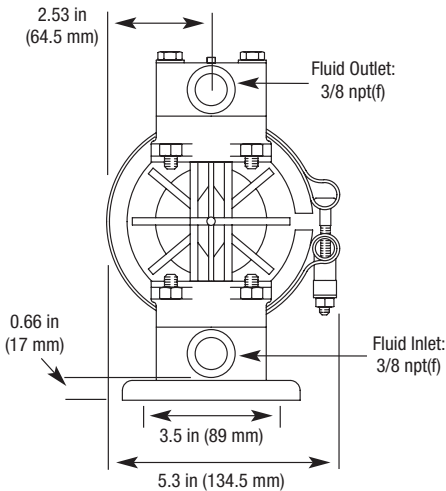
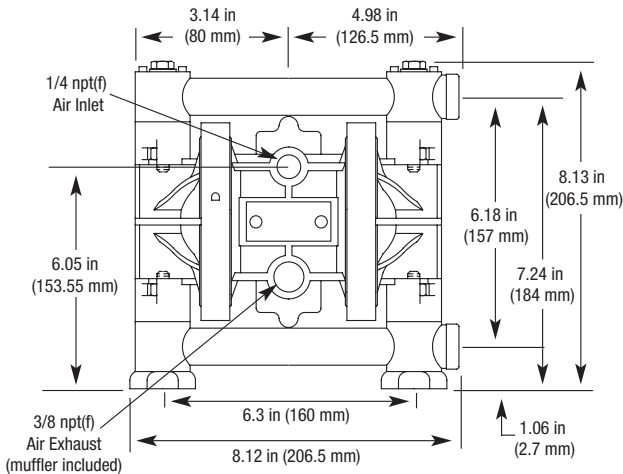

Typical System Drawings

Husky 307 Wall-Mount with Siphon Feed

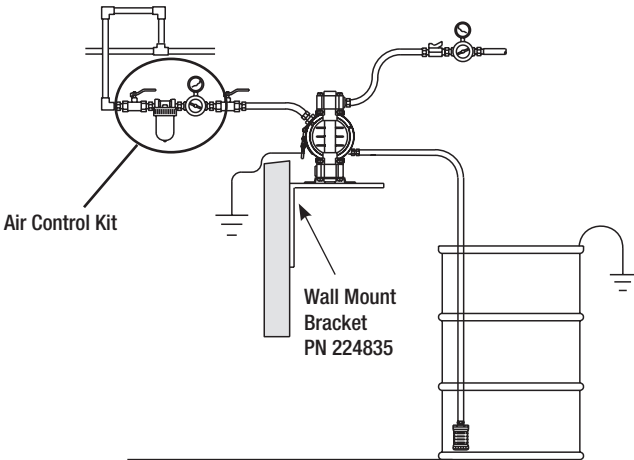

Husky 307 Drum-Mount with Siphon Feed

